

# Drawer Magnet Housing Flange/Accessory Form

## SPECIFY:

See next page for Isometric/ 3 Dimensional View

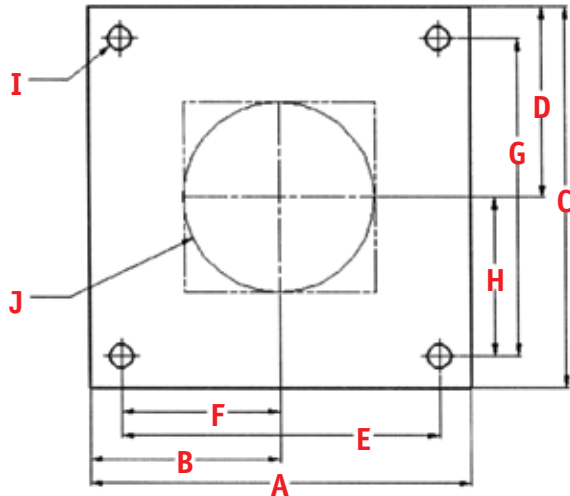

**Bottom Flange  
Operator Side (Front)**

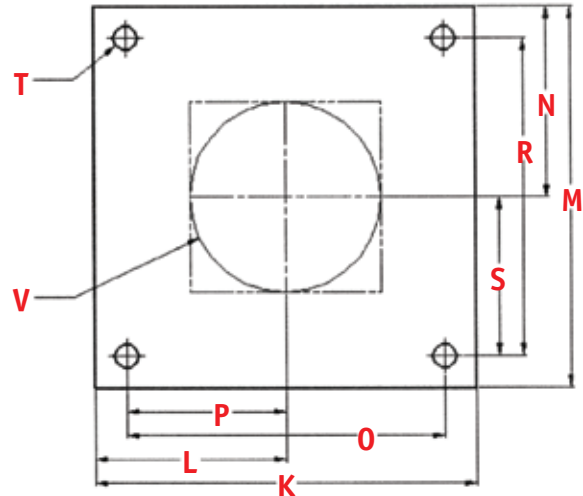

**Top Flange  
Operator Side (Front)**

**A** \_\_\_\_\_ **H** \_\_\_\_\_  
**B** \_\_\_\_\_ **I** \_\_\_\_\_ (bolt size used)  
**C** \_\_\_\_\_ **J** — **Opening**  
 Round \_\_\_\_\_  
 Square \_\_\_\_\_  
 Rectangle \_\_\_\_\_  
**E** \_\_\_\_\_ Front to Back \_\_\_\_\_  
**F** \_\_\_\_\_ Side to Side \_\_\_\_\_  
**G** \_\_\_\_\_

**K** \_\_\_\_\_ **S** \_\_\_\_\_  
**L** \_\_\_\_\_ **T\*** \_\_\_\_\_  Threaded Holes  
(thread size used)  Studs  
**M** \_\_\_\_\_ **V** — **Opening**  
 Round \_\_\_\_\_  
 Square \_\_\_\_\_  
 Rectangle \_\_\_\_\_  
**N** \_\_\_\_\_ Front to Back \_\_\_\_\_  
**O** \_\_\_\_\_ Side to Side \_\_\_\_\_  
**P** \_\_\_\_\_  
**R** \_\_\_\_\_

\*Studs will be required if bolt pattern falls on housing body

Make of Press: \_\_\_\_\_ Serial Number: \_\_\_\_\_

Model: \_\_\_\_\_ Screw Size: \_\_\_\_\_ Ounce: \_\_\_\_\_

Make of Hopper: \_\_\_\_\_ Hopper Capacity: \_\_\_\_\_ lbs.

Optional Equipment:

Slide Gate Shut-off  With Discharge Dump Tube:  Rear  Other \_\_\_\_\_  
 Tapped Hole for Liquid Dispensing System  With Purge Hopper:  R.H. Side  L.H. Side  
 Other \_\_\_\_\_

Date: \_\_\_\_\_ Quantity: \_\_\_\_\_ Phone: (\_\_\_\_\_) \_\_\_\_\_ Fax: (\_\_\_\_\_) \_\_\_\_\_

Name: \_\_\_\_\_ Title: \_\_\_\_\_

Company Name: \_\_\_\_\_ Email: \_\_\_\_\_

Address: \_\_\_\_\_

City: \_\_\_\_\_ State: \_\_\_\_\_ Zip: \_\_\_\_\_



[www.imscompany.com](http://www.imscompany.com)

phone order toll-free (USA & Canada) **1.800.537.5375**

fax order toll-free (USA & Canada)

phone order toll-free (Mexico)

tech support toll-free (USA & Canada)

e-mail

**1.888.288.6900**

**001.888.304.1307**

**1.866.467.9001**

**sales@imscompany.com**

Please refer to [imscompany.com](http://imscompany.com) for current pricing ©Copyright 2021 IMS Company. All rights reserved.

# Isometric View of Flange Dimensions

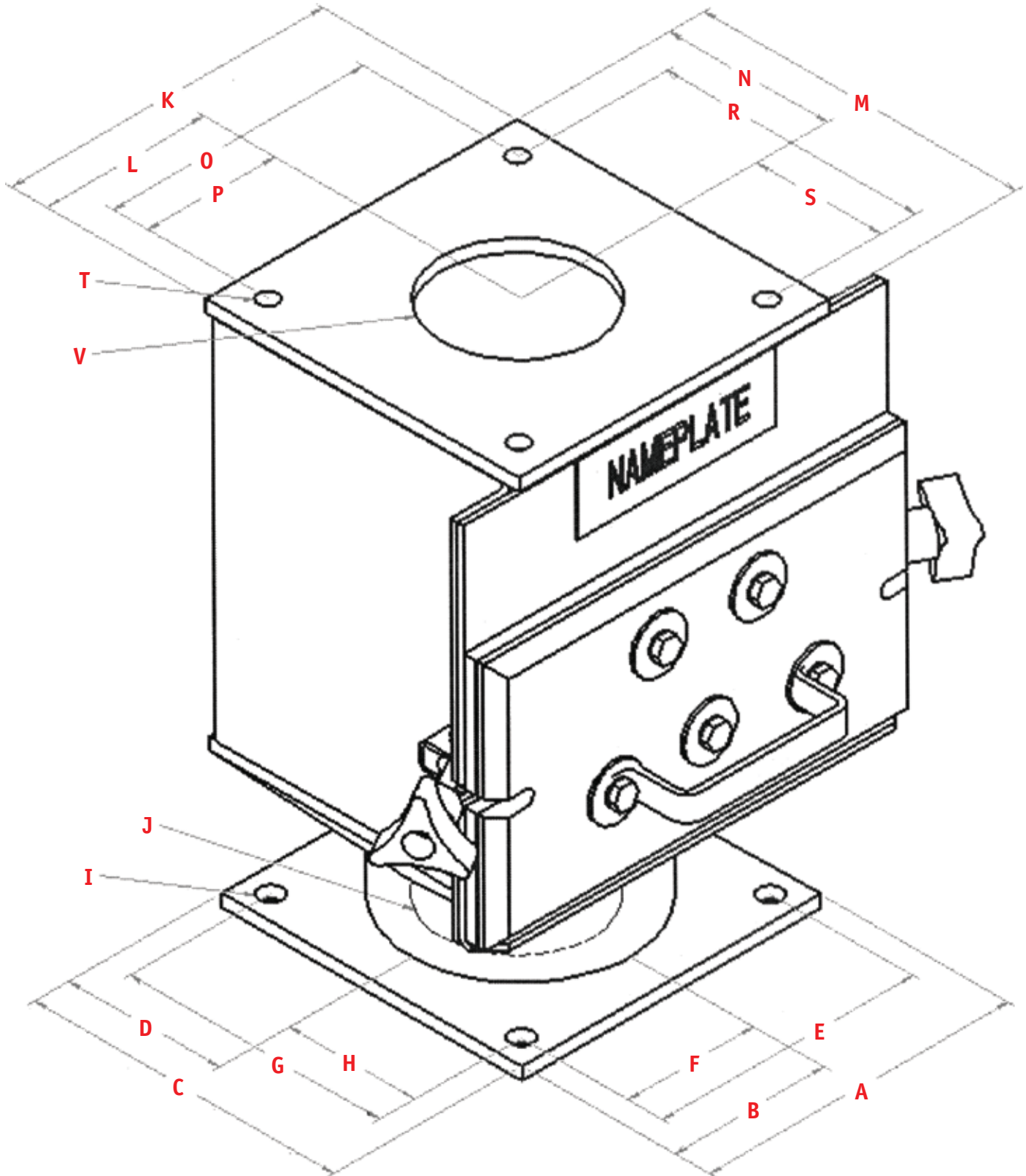

[www.imscompany.com](http://www.imscompany.com)

phone order toll-free (USA & Canada) **1.800.537.5375**

fax order toll-free (USA & Canada)  
**1.888.288.6900**

phone order toll-free (Mexico)  
**001.888.304.1307**

tech support toll-free (USA & Canada)  
**1.866.467.9001**

e-mail  
**sales@imscompany.com**

Please refer to [imscompany.com](http://imscompany.com) for current pricing ©Copyright 2021 IMS Company. All rights reserved.